

02 - 04.2

10.05.GB

**Control valves
RV 805 and RV 806**



Kv coefficient calculation

Calculation itself is carried out with respect to conditions of regulating circuit and operating medium according to equations mentioned below. Control valve must be designed to be able to regulate maximal flow quantity at given operating conditions. At the same time it is necessary to check whether minimal flow quantity can be even regulated or not.

Because of eventual minus tolerance 10% of Kv_{100} against Kvs and requirement for possible regulation within range of maximal flow (decrement and increase of flow), producer recommends to select Kvs value higher than maximal operating Kv value:

$$Kvs = 1.2 \div 1.3 Kv$$

It is necessary to take into account to which extent Q_{max} involve "precautionary additions" that could result in valve oversizing.

Relations of Kv calculation

		Pressure drop $p_2 > p_1/2$ $\Delta p < p_1/2$	Pressure drop $\Delta p \geq p_1/2$ $p_2 \leq p_1/2$
Kv =	Liquid	$\frac{Q}{100} \sqrt{\frac{\rho_1}{\Delta p}}$	
	Gas	$\frac{Q_n}{5141} \sqrt{\frac{\rho_n \cdot T_1}{\Delta p \cdot p_2}}$	$\frac{2 \cdot Q_n}{5141 \cdot p_1} \sqrt{\rho_n \cdot T_1}$
	Superh. steam	$\frac{Q_m}{100} \sqrt{\frac{v_2}{\Delta p}}$	$\frac{Q_m}{100} \sqrt{\frac{2v}{p_1}}$
	Sat. steam	$\frac{Q_m}{100} \sqrt{\frac{v_2 \cdot x}{\Delta p}}$	$\frac{Q_m}{100} \sqrt{\frac{2v \cdot x}{p_1}}$

Above critical flow of vapours and gases

When pressure ratio is above critical ($p_2/p_1 < 0.54$), speed of flow reaches acoustic velocity at the narrowest section. This event can cause higher level of noisiness and then it is convenient to use a throttling system ensuring low noisiness (multi-step pressure reduction, damping orifice plate at outlet).

Dimensions and units

Marking	Unit	Name of dimension
Kv	m ³ /hour	Flow coefficient under conditions of units of flow
Kv_{100}	m ³ /hour	Flow coefficient at nominal stroke
Kvs	m ³ /hour	Valve nominal flow coefficient
Q	m ³ /hour	Flow rate in operating conditions (T_1, p_1)
Q_n	Nm ³ /hour	Flow rate in normal conditions (0 °C, 0.101 MPa)
Q_m	kg/hour	Flow rate in operating conditions (T_1, p_1)
p_1	MPa	Upstream absolute pressure
p_2	MPa	Downstream absolute pressure
p_s	MPa	Absolute pressure of saturated steam at given temperature (T_1)
Δp	MPa	Valve differential pressure ($\Delta p = p_1 - p_2$)
ρ_1	kg/m ³	Process medium density in operating conditions (T_1, p_1)
ρ_n	kg/Nm ³	Gas density in normal conditions (0 °C, 0.101 MPa)
v_2	m ³ /kg	Specific volume of steam when temperature T_1 and pressure p_2
v	m ³ /kg	Specific volume of steam when temperature T_1 and pressure $p_1/2$
T_1	K	Absolute temperature at valve inlet ($T_1 = 273 + t_1$)
x	1	Proportionate weight volume of saturated steam in wet steam

Cavitation

Cavitation is a phenomenon when there are steam bubbles creating and vanishing in shocks - generally at the narrowest section of flowing due to local pressure drop. This event expressively cuts down service life of inner parts and can result in creation of unpleasant vibrations and noisiness. In control valves it can happen on condition that

$$(p_1 - p_2) \geq 0.6 (p_1 - p_s)$$

Valve differential pressure should be set the way so that neither any undesired pressure drop causing cavitation can occur, nor liquid-steam(wet steam) mixture can create. Otherwise it must be taken into account when calculating Kv value. If the creation of cavitation still threatens, it is necessary to use a multi-step pressure reduction.

Valve flow characteristics

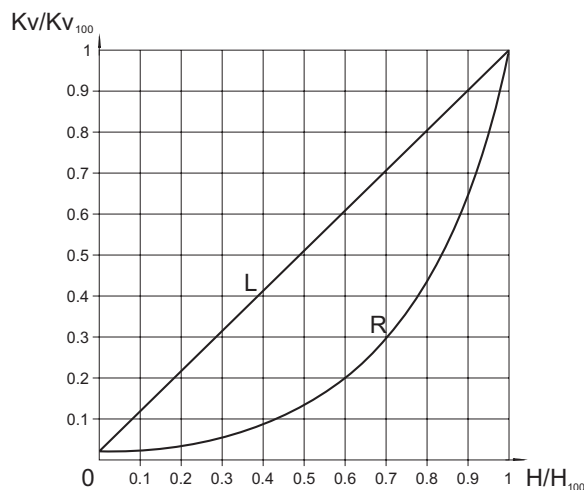

L - linear characteristic

$$Kv/Kv_{100} = 0.0183 + 0.9817 \cdot (H/H_{100})$$

R - equal-percentage characteristic (4-percentage)

$$Kv/Kv_{100} = 0.0183 \cdot E^{(4 \cdot H/H_{100})}$$

Diagram for the valve Kvs value specification according to the required flow rate of water Q and the valve differential pressure Δp

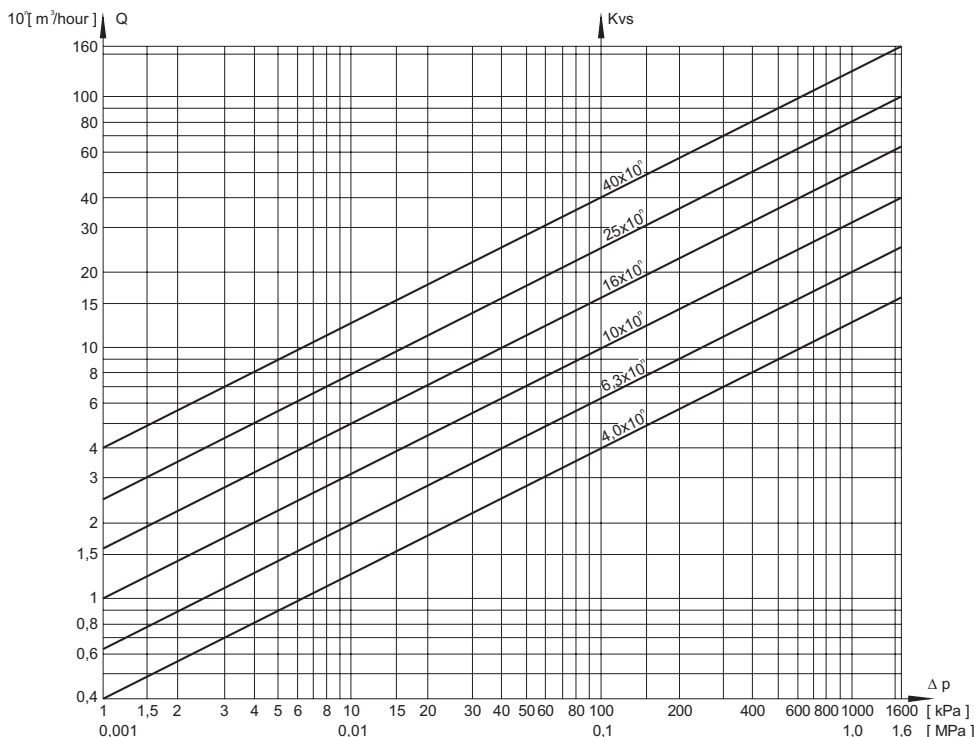

The diagram serves to specify the valve Kvs value regarding to the required flow rate of water at a given differential pressure. It can be also used for finding out the differential pressure value of the existing valve in behaviour with the flow rate. The diagram applies to water with the density of 1000 kg/m³.

For the value $Q = q \cdot 10^n$, it is necessary to calculate with $Kvs = k \cdot 10^n$. Example: water flow rate of $16 \cdot 10^{-1} = 1,6 \text{ m}^3/\text{hour}$ corresponds to $Kv = 2,5 = 25 \cdot 10$ when differential pressure 40kPa.

Application of multi-step pressure reduction

When the valves are designed for operating in a differential pressure higher than recommended or in above-critical differential pressure ($p_1/p_2 < 0,54$ when throttling steam and

gases), it is effectual to use a throttling system in two or three steps to prevent the cavitation from creating and to ensure both a long service life of the valve inner parts and low noisiness when operating.

Type of trim: cage - perforated plug

Two-step pressure reduction

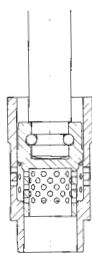

Three-step pressure reduction

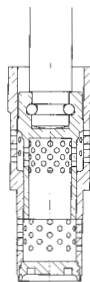

Four-step pressure reduction

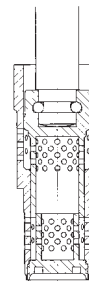

Type of trim: seat - parabolic plug

One-step pressure reduction

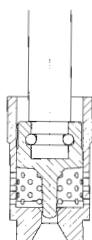

Two-step pressure reduction

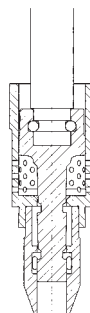

Three-step pressure reduction

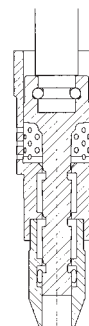

RV 805 RV 806

**Control valves
DN 25, 40, 50
PN 160, 250, 400**



Description

The control valves series RV 805 and RV 806 are single-seated valves of a unit construction that provides a great variety of control elements. Thanks to such a combination, it is possible to satisfy the customers' requirements and demands. The valve is equipped with "Live Loading" packing.

The valve connection is weld ends in angle execution (type RV 805) or "Z"-shaped execution (RV 806). Material of weld ends is optional. The dimensions of connection correspond to ČSN 13 1075 and their shape to EN 12 627.

The valve can also be supplied with the connection specified by the customer. The valve is supplied with an electric actuators of the following producers: ZPA Pečky, ZPA Křižik Prešov, Auma, Schiebel and EMG -Drehmo.

Process media

The valves are especially designed to control the flow and pressure of cooling water to steam. The producer recommends to pipe a strainer into pipeline in front of the valve when impurities are present. Impurities can affect the quality and reliability of regulation and can cause a reduction of the valve service life. It is necessary to take into account the used materials when the valves is used for any other process media.

Technical data

Series	RV 805		RV 806	
Type of valve	Control valve, single-seated, angle, with weld ends		Control valve, single-seated, "Z"- shaped, with weld ends	
Nominal size range	25, 40, 50			
Nominal pressure	160, 250, 400			
Body material	Stainless steel 1.4922 (X20CrMoV11-1)			
Material of weld ends	Cast steel 1.0425 (P 265 GH)	Alloy steel 1.7335 (13CrMo4-5)	Cast steel 1.0425 (P 265 GH)	Alloy steel 1.7335 (13CrMo4-5)
Operating temp. range	-20 to 400 °C	-20 to 550 °C	-20 to 400 °C	-20 to 550 °C
Connection	Weld ends acc. to ČSN 13 1075 (3/1991)			
Type of trim	Cage - perforated plug; seat - contoured plug (for small Kvs values)			
Δp_{max} for 1 step of reduction	4,0 MPa for perforated plug, 2,0 MPa for contoured plug			
Flow characteristic	Linear, equal-percentage acc. to ČSN EN 60534-1 (4/1997)			
Leakage rate	Class IV. acc. to ČSN EN 1349 (5/2001)			

Range of Kvs values

DN	25	40	50	25	40	50
	Kvs values [m ³ /h]					
Multi-step press. red.	Linear characteristic			Equal-percentage characteristic		
	Type of trim: cage - perforated plug					
2	2.5 - 4.0	2.5 - 8.0	2.5 - 12.5	3.2 - 4.0	3.2 - 8.0	3.2 - 10.0
3	2.0 - 3.2	2.0 - 6.3	2.0 - 9.0	2.8 - 3.2	2.8 - 6.3	2.8 - 9.0
4	1.6 - 2.8	1.6 - 5.6	1.6 - 7.1	2.5 - 2.8	2.5 - 5.6	2.5 - 7.1
	Type of trim: seat - contoured plug					
1	0.63 - 4.5			1.6 - 4.5		
2	1.0 - 2.24			1.4 - 2.8		
3	0.8 - 1.8			1.0 - 2.5		

Application

The valves series RV 805 and RV 806 are especially designed as control elements for control of injection water supply into steam pipeline. Thanks to their high nominal working pressure (PN 400) and ability to manage high differential pressures (ordinarily 15 MPa, max. 20 MPa), owing to a multi-step pressure reduction, the valves can be used in every application to which any other common valve cannot resist due to its low service life. The max. permissible operating pressures correspond to EN 12 516-1 also mentioned on the page 18 of this catalogue.

Installation

The valve can be piped in any way except the position when the actuator is under the valve body, The flow direction is indicated by the arrows on the valve body.

Dimensions and weights for the type RV 805

DN	PN 160, 250, 400		PN 160		PN 250		PN 400		m
	L	H	D	t	D	t	D	t	
[mm]	[mm]	[mm]	[mm]	[mm]	[mm]	[mm]	[mm]	[mm]	[kg]
25	160	25	33.7	4	33.7	5	33,7	8.5	34
40	165	25	48.3	5	48.3	7	48.3	11	35
50	175	25	60.3	6.3	60.3	8	60.3	12.5	36

Dimensions and weights for the type RV 806

DN	PN 160, 250, 400		PN 160		PN 250		PN 400		m
	L	H	D	t	D	t	D	t	
[mm]	[mm]	[mm]	[mm]	[mm]	[mm]	[mm]	[mm]	[mm]	[kg]
25	320	25	33.7	4	33.7	5	33,7	8.5	34
40	330	25	48.3	5	48.3	7	48.3	11	35
50	350	25	60.3	6.3	60.3	8	60.3	12.5	36

Control valve RV 805 angle

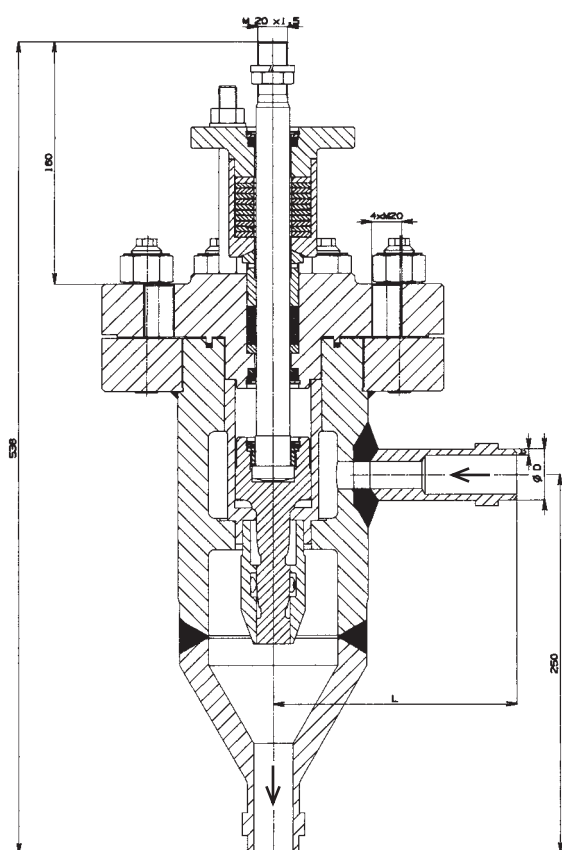

Control valve RV 806 "Z"-shaped

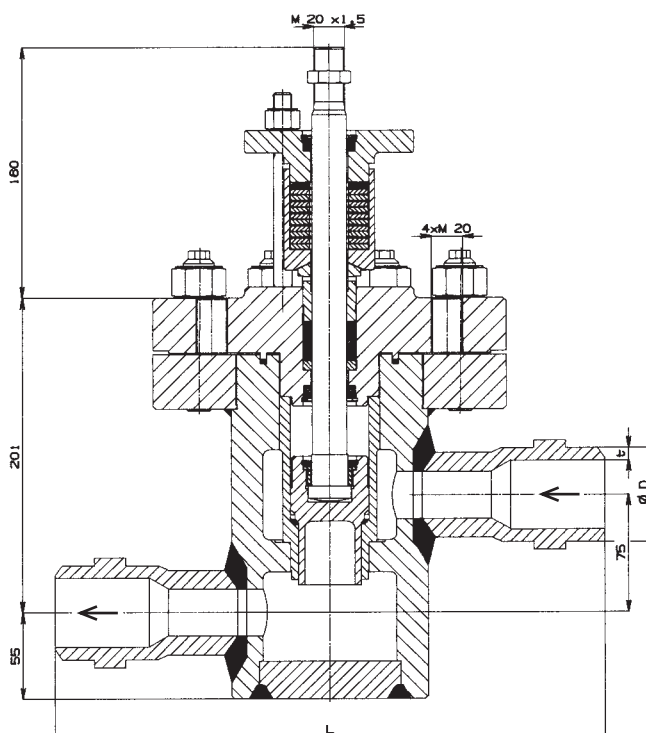

Valve complete specification No. for ordering RV 805 and RV 806

		XX	XXX	XXX	XXXX	XX	-	XXX	/	XXX	-	XX
1. Valve	Control valve	RV										
2. Series	Control valve, straight-through		8 0 5									
	Control valve "Z"-shaped		8 0 6									
3. Type of actuating	Electric actuator			E								
	Pneumatic actuator			P								
	Electric actuator Modact MTR			E P D								
	Electric actuator Modact MTN Control			E Y A								
	Electric actuator Modact MTN			E Y B								
	Electric actuator Modact MOP 52 030			E Y E								
	Electric actuator Modact MOP Control 52 030			E Y F								
	Electric actuator Modact MOP 52 031			E Y G								
	Electric actuator Modact MOP Control 52 031			E Y H								
	Electric actuator Auma SAR 07.5			E A G								
	Electric actuator Auma SAR 10.1			E A J								
	Electric actuator Schiebel rAB8			E Z K								
Electric actuator Foxboro PO 1502			P F D									
4. Connection	Weld ends				4							
5. Weld ends material <i>(operating temp. ranges are specified in the parentheses)</i>	Cast steel 1.0425 (P 265 GH) (-20 to 400°C)				2							
	Alloy steel 1.7335 (13CrMo4-5) (-20 to 550°C)				6							
	Other material on request				9							
6. Packing	Graphite - Live Loading				5							
7. Multi-step pressure reduction	One-step pressure reduction				1							
	Two-step pressure reduction				2							
	Three-step pressure reduction				3							
	Four-step pressure reduction				4							
8. Flow characteristic	Linear					L						
	Equal-percentage					R						
9. No. of orifice plate	Without					0						
10. Nominal pressure PN	PN 160							160				
	PN 250							250				
	PN 400							400				
11. Operating temperature °C	Acc. to process medium								XXX			
12. Nominal size	DN - acc. to the valve selection										XX	

Order example : Control valve, angle, injecting, DN 40, PN 250, with electric actuator Modact Control MTN, body material: wrought carbon steel, packing: graphite, three-step pressure reduction, with linear flow characteristic, is specified as follows : **RV 805 EYA 4253 L0 250/400-40.**

Note

A different type of actuating can be delivered after agreement with the producer.



Electric actuator Modact MTR Regada

Technical data

Type	Modact MTR
Marking in valve specification No.	EPD
Voltage	230 V
Frequency	50 / 60 Hz
Motor power	16 or 25 W
Control	3 - pos. c. (in connection with NOTREP positioner - continuous)
Nominal force	10, 16, 25 kN
Travel	12,5 to 100 mm
Enclosure	IP 54 (IP 65 on request)
Process medium max. temperature	Acc. to used valve
Ambient temperature range	-25 to 50°C
Ambient humidity limit	90 %
Weight	27 to 31 kg

Dimensions of Modact MTR

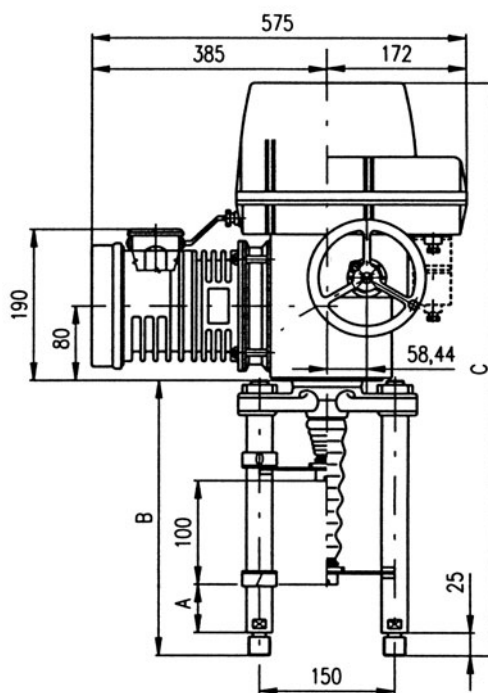
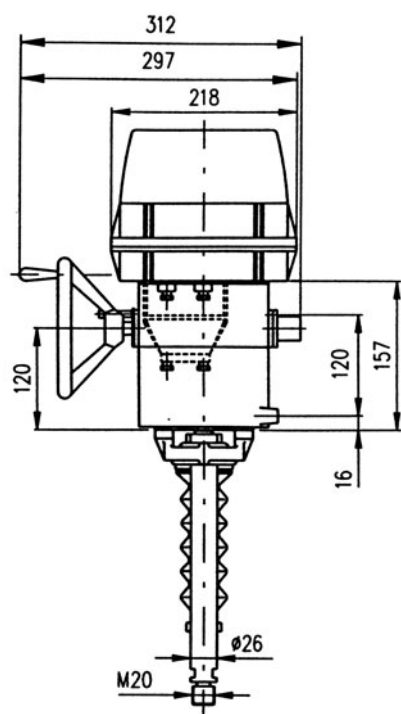

Detail of coupling

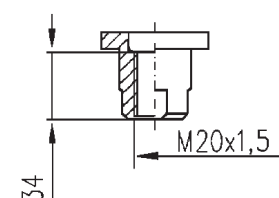

Columns	with ball bolt			
	verze	A	B	C
P-1045a/H	130	400	729	

Specification of Modact MTR

Electric actuator MTR, linear							52 420.	X	-	X	X	X	X	X	/	X	X					
Mild up to hot dry with temperature range (-25 °C to +50 °C)							0															
Electric connection		Voltage			Wiring diagram																	
To terminal board		230 V AC			Z296																	
To connector									9													
Screw version		Switching-off thrust ¹⁾²⁾	Rated operating speed	Operating speed	Electric motor																	
ball screw	25 000/32-G				Power	Speed	Current															
			25 W	1 250	0.41 A																	
Control board version		Operating stroke			Wiring diagram																	
Electromechanical control board - without local control		25 mm			Z298																	
Transmitter		Connection		Output		Wiring diagram																
Without transmitter		—		—		—																
Resistive	Single		—	1x100 Ω		Z5a																
	Double			2x100 Ω		Z6a																
	Single			1x2000 Ω		Z5a																
	Double			2x2000 Ω		Z6a																
Resistive with current converter	Without power supply		2-wire	4 - 20 mA		Z10a																
	With power supply			Z269a																		
	Without power supply		3-wire	0 - 20 mA		Z257a																
	With power supply			Z260a																		
	Without power supply			4 - 20 mA		Z257a																
	With power supply			Z260a																		
	Without power supply			0 - 5 mA		Z257a																
	With power supply			Z260a																		
Capacitive CPT	Without power supply		2-wire	4 - 20 mA		Z10a																
	With power supply			Z269a																		
Mechanical connection	Connecting height / stroke		Pillar spacing / Bore of flange		Thread of stem ³⁾		Dimensional drawing															
Columns	130/100		150/ —		M20x1.5		P-1045a/C; P-1045a/H															
Additional equipment							Wiring diagram															
Without additional equipment; adjusted max. switching-off thrust from range																					0 1	
A	2 additional position switches S5,S6						Z298														0 2	
B	Adjustment of switching-off thrust for required value																				0 3	

Combinations available and specification codes: A+B = 07

Notes:

- 1) State the switching-off thrust in your order by words. If not stated it is adjusted to the maximum rate of the corresponding range. The load torque equals minimally the maximum switching-off thrust of the choosing range multiplied by 1.3.
- 2) The maximum load thrust equals the max. Switching-off thrust multiplied by:
 - 0.8 for duty cycle S2-10 min., Or S4-25%, 6 - 90 cycles per hour
 - 0.6 for duty cycle S4-25%, 90 - 1200 cycles per hour
- 3) The thread in the coupling is to be specified in the order by words.

Wiring diagram of actuator Modact MTR

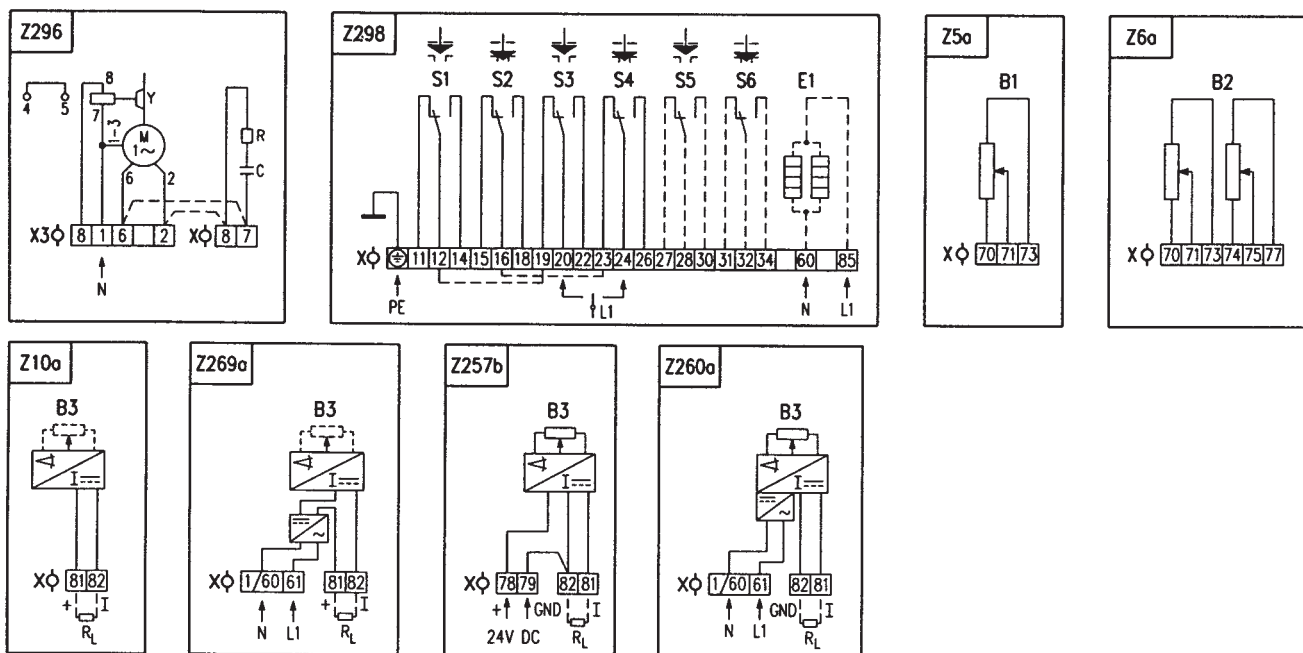

Notes:

1. For the EA version with connection to the terminal board, the terminal 1/60 (the wiring diagrams Z269a and Z260a) is leaded out to the terminal No. 1.
2. For EA version with connection to the terminal board the actuator is not equipped by the jumper X3:6-X:7 and X3:2-X:8 (Z296) from manufacturing plant (it is necessary to connect it by customer).

Legend:

Z5a connection of single resistive transmitter
 Z6a connection of double resistive transmitter
 Z10a connection of resistive with current converter of capacitive transmitter - 2-wire without supply
 Z257b connection of resistive transmitter with current converter - 3-wire
 Z260a connection of resistive transmitter with current converter - 3-wire with power supply
 Z269a connection of resistive transmitter with current converter or capacitive transmitter - 3-wire with power supply
 Z296 connection of 1-phase electric motor
 Z298 connection of thrust and position switches and space heater

B1 resistive transmitter (potentiometer) single
 B2 resistive transmitter (potentiometer) double
 B3 capacitive transmitter
 S1 thrust switch "open"
 S2 thrust switch "closing"
 S3 position switch "open"
 S4 position switch "closed"
 S5 additional position switch "open"
 S6 additional position "closed"
 M motor
 C capacitor
 Y motor's brake
 E1 space heater
 X terminal board
 X3 electric motor's terminal board
 I/U input (output) current (voltage) signals
 R reducing resistor
 R_L loading resistor

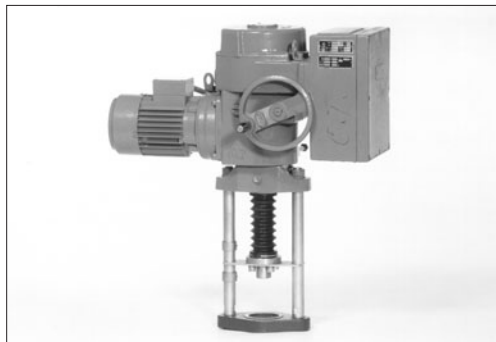

Electric actuators Modact MTN and Modact MTN Control ZPA Pečky

Technical data

Type	Modact MTN Control	Modact MTN
Marking in valve specification No.	EYA	EYB
Voltage	3 x 230 V / 400 V (3 x 220 V / 380 V)	
Frequency	50 Hz	
Motor power	See specification table	
Control	3 - position control or continuous	
Nominal force	25000 N	
Travel	25 mm	
Enclosure	IP 55	
Process medium max. temperature	Acc. to used valve	
Ambient temperature range	-25 to 55 °C	
Ambient humidity range	10 - 100 % with condensation	
Weight	45 kg	

Wiring diagram of actuator Modact MTN

Execution - terminal board

Position transmitter : resistance 2x100 W or without

Position transmitter : capacity CPT 1 1/A 4 - 20 mA

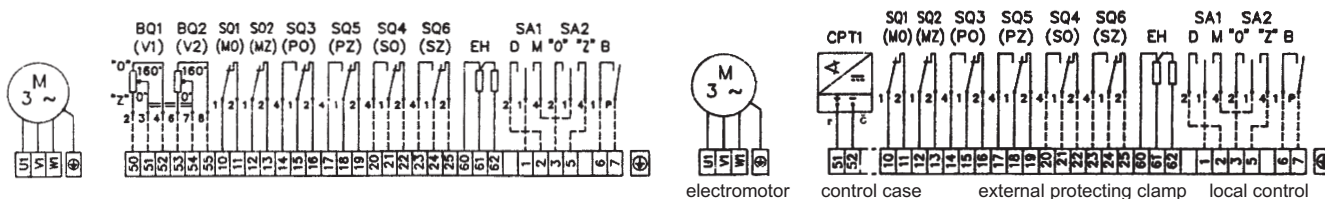

Wiring diagram of actuator Modact MTN Control

With current transmitter, built-in contactor combination, brake BAM and positioner.

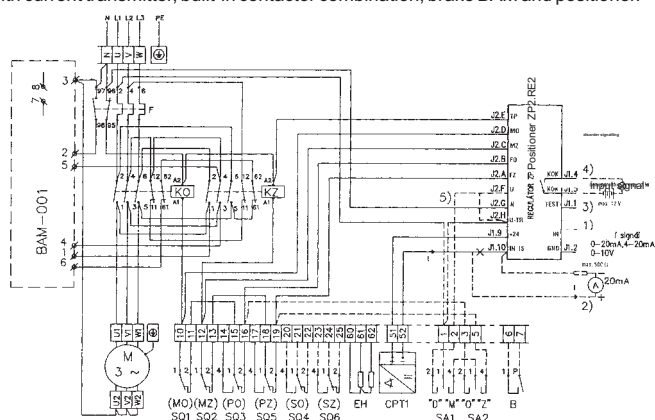

- SQ1 (MO) power switch in "opening" direction
- SQ2 (MZ) power switch in "closing" direction
- SQ3 (PO) limit switch in "opening" direction
- SQ5 (PZ) limit switch in "closing" direction
- SQ4 (SO) signalisation switch in "opening" direction
- SQ6 (SZ) signalisation switch in "closing" direction
- EH heaters 2 x TR 551 10k/A
- CPT1 capacity position transmitter CPT1/A 4 - 20 mA
- BAM-001 dynamic brake
- KO contactor in "opening" direction
- KZ contactor in "closing" direction
- F thermal relay
- SA1 control switch "local - remote"
- SA2 switch "open - close"
- BQ1, BQ2 position transmitter 2 x 100 W
- ZP2.RE electronic positioner

Connection dimensions - details of additional specification No. of 52 442

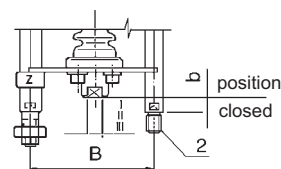

Pitch of columns	B	150
Position "closed"	b	130
Clutch thread	I	M 20x1,5

Execution	Specification No.	
	basic	additional
Bb2I	52 442	XRXXN

Specification of actuators Modact MTN and Modact MTN Control

Basic equipment :	2 power switches MO, MZ	1 position transmitter - resist. 2x100 W or cap. CPT1/A
	2 limit switches PO, PZ	2 limit switches PO, PZ
	2 limit and signalisation switches SO, SZ	2 limit and signalisation switches SO, SZ

Basic technical data :

Type	Power switch setting range kN	Direct power kN	Resetting speed mm.min ⁻¹	Travel mm	Electromotor				Weight		Specification No.	
					Power W	rpm	In (400V) A	Iz / In	Aluminium	Cast	Basic	Additional
MT 25	15 - 25	32,5	50	10 - 100	180	900	0.67	2.5	33	45	52 442	XX4X
			80		180	900	0.67	2.5				XX5X
			125		250	1380	0.77	3.4				XX6X
			36		120	660	0.67	2.2				XX7X
			27		120	660	0.67	2.2				XX8X

Execution, electric connection :

Via terminal board	6XXX	
With conector KBSN (for Modact MTN execution only)	7XXX	
Transmitter for Modact MTN	Capacity transmitter CPT 1/A 4 - 20 mA	XXX0
	Resistance transmitter 2 x 100 Ω	XXX2

Additional electric equipment

		With resistance transmitter 2x100 W	With capacity transmitter CPT 1/A
Modact MTN execution	With local control - terminal board	XXX3	XXX1
	With unlock control - conector KBNS	XXX3	XXX1
Modact MTN Control execution (with built-in contactor combination)	Without local control	Without brake BAM and positioner	XXX4
		With brake BAM, without positioner	XXX5
		With brake BAM and with positioner	
	With local control	Without brake BAM and positioner	XXX7
		With brake BAM, without positioner	XXX8
		With brake BAM and positioner	XXXF

Note : When execution with flasher is requested, please specify this requirement in writing - execution with flasher.

Dimensions of actuator Modact MTN Dimensions of actuator Modact MTN Control

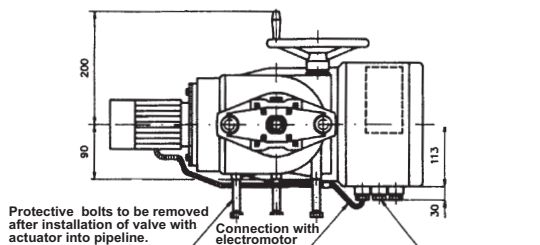
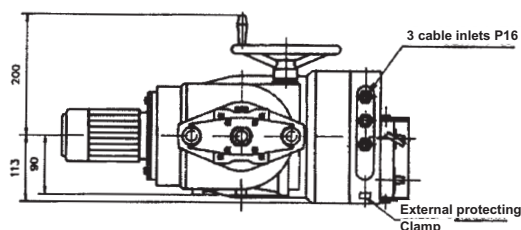

A	160
B	150
a	30
b	74
g	130
c (a)	308
d (b)	352
e (a)	615
f (b)	659
ch (g)	715

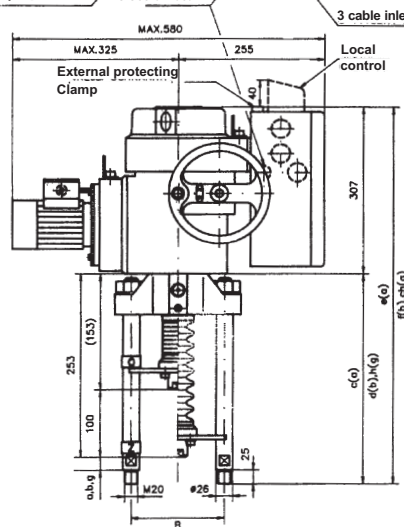
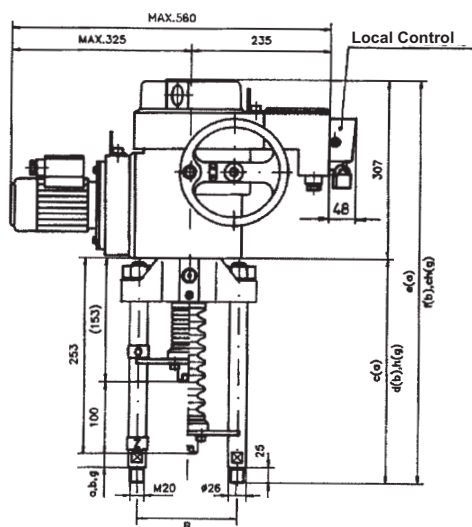

Detail of coupling

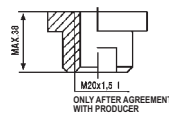

EYE, EYF EYG, EYH



Electric actuators Modact MOP and Modact MOP Control ZPA Pečky

Technical data

Type	52 030 MOP	52 030 MOP Control	520 31 MOP	52 031 MOP Control
Marking in valve specification No.	EYE	EYF	EYG	EYH
Voltage	3x 230/400 V			
Frequency	50 Hz			
Motor power	See specification table			
Control	3 - position control or continuous			
Nominal force	20 Nm			
Travel	Acc. to given stroke			
Enclosure	IP 67			
Process medium max. temperature	Acc. to used valve			
Ambient temperature range	acc. to ČSN 33 2000-3, class AA7, AB7, AC1, AD5, AE5, AF2, AG2, AH2, Ak2, AL2, AM2, AN2, AP3, BA4, BC3			
Working condition	Loading S2 acc. to ČSN EN 60 034-1			
Weight	23 - 36 kg		33 - 59 kg	

Dimensions of Modact MOP

DIMENSIONAL DRAWING OF ACTUATORS MODACT MOP

52 030 a 52 031 EXECUTION WITH TERMINAL BOARD

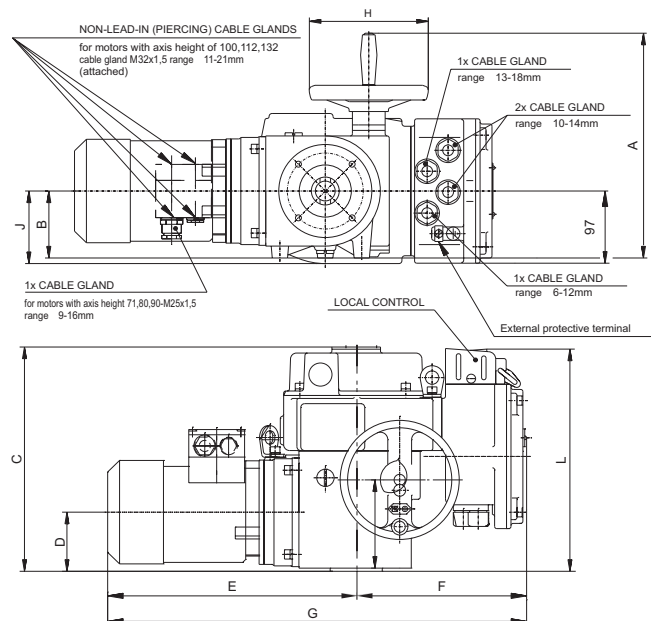

DIMENSIONAL DRAWING OF ACTUATORS MODACT MOP

52 030 a 52 031 EXECUTION WITH CONECTOR

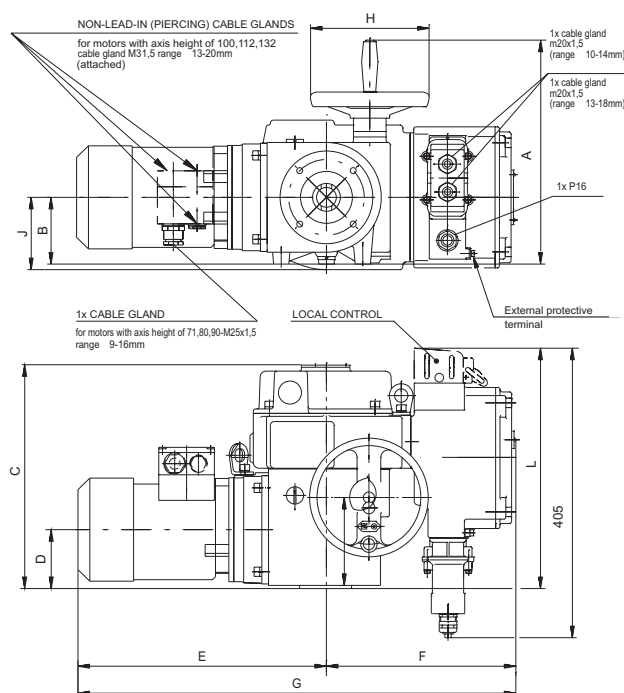

Type marking	A	B	C	D	E	F	G	H	J	K	L
52 030	305	90	300	78	334	228	562	160	99	120	300
52 031	376	120	328	92	436	228	664	200	-	144	328

Type marking	A	B	C	D	E	F	G	H	J	K	L
52 030	305	90	300	78	334	258	592	160	99	120	325
52 031	376	120	328	92	436	258	694	200	-	144	350

DIMENSIONAL DRAWING OF ACTUATORS MODACT MOP CONTROL

52 030 a 52 031

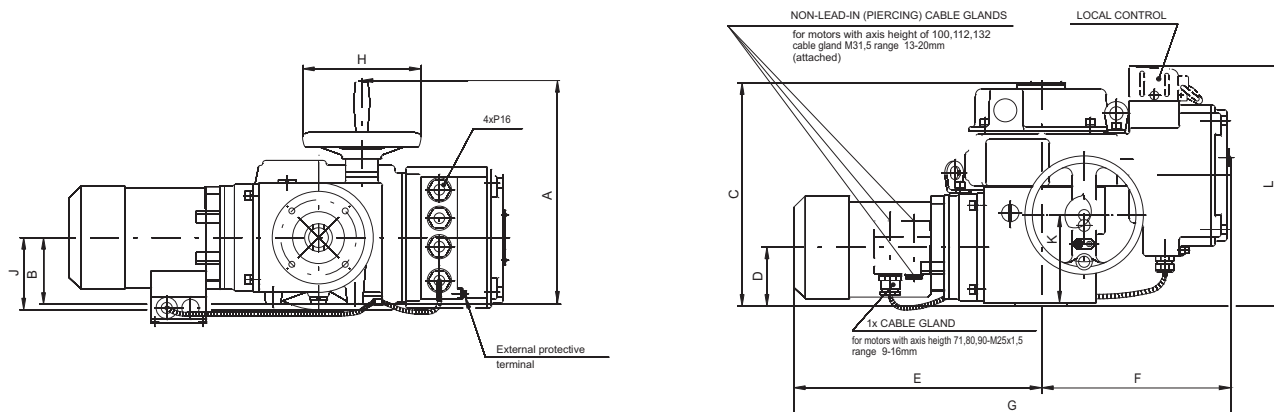

Type marking	A	B	C	D	E	F	G	H	J	K	L
52 030	305	90	300	78	334	258	592	160	99	120	325
52 031	376	120	328	92	436	258	694	200	-	144	328

Specifikace pohonu Modact MOP

Connection dimensions		Output shaft type A	Via terminal board	XX XXX	X	X	X	X	X			
			With connector		5							
					F							
Local control, position indicator												
Resistance transmitter or execution without transmitter		Without local control, without position indicator						1				
		Local control						4				
		Local control for actuators Modact MOP Control						7				
Capacity transmitter CPT 1/A		Without local control, without position indicator						B				
		Local control						E				
		Local control for actuators Modact MOP Control						H				
Type marking	Moment		Running speed	Stroke	Electromotor							
	Tripping	Driving			Power	rpm	I_n (400V)	I_z / I_n				
	(Nm)	(Nm)										
MOP 80/135 - 7	40-80	135	7	2-250	0,09	630	0,36	2,2	52 030			K
MOP 80/140 - 9		140	9		0,12	890	0,60	2,5			6	
MOP 80/135 - 15		135	15		0,18	835	0,62	2,3			7	
MOP 80/105 - 25		105	25		0,25	1350	0,76	3,0			8	
MOP 100/130 - 9	63-100	130	9		0,12	890	0,60	2,5	52 031			0
MOP 100/130 - 15		130	15		0,25	850	0,78	2,7			1	
MOP 100/150 - 25		150	25		0,37	920	1,20	3,1			2	
MOP 100/170 - 40		170	40		0,55	1395	1,45	3,9			3	
MOP 100/150 - 63		150	63		0,75	1395	1,86	4,0			4	
MOP 100/200 - 80		200	80		1,1	2845	2,40	6,1			E	
MOP 100/150 - 100		150	100		1,1	1410	2,65	4,3			5	
MOP 100/150 - 145		150	145		1,5	2860	3,30	5,5			F	

the table continues on next page

continuation of the table of the specification of Modact MOP from the previous page

		XX XXX	X	X	X	X	X	
Signalization, position transmitter, blinker								
Only for actuators Modact MOP	Without signalisation, position transmitter and blinker						0	
	Position transmitter						1	
	Signalization switches						2	
	Signalization switches and position transmitter						3	
	Blinker						4	
	Position transmitter, blinker						5	
	Signalization switches and blinker						6	
	Signalization switches, position transmitter, blinker						7	
Signalization, position transmitter, blinker								
Only for actuators Modact MOP Control	Complete equipment Sch P-0781	Position transmitter					A	
		Signalization switches and position transmitter					B	
		Position transmitter, blinker					C	
		Signalization switches, position transmitter and blinker					D	
	Without positioner	Without signalization, without posit. transmitter and blinker						E
		Position transmitter						F
		Signalization switches						G
		Signalization switches and position transmitter						H
		Blinker						I
		Position transmitter, blinker						J
		Signalization switches, blinker						K
		Signalization switches, position transmitter and blinker						L
	Without positioner and brake BAM	Without signalization, without position transm. and blinker						M
		Position transmitter						N
		Signalization switches						O
		Signalization switches and position transmitter						P
		Blinker						R
		Position transmitter, blinker						S
		Signalization switches, blinker						T
		Signalization switches, position transmitter and blinker						U
This mark is valid for the the types of the actuators							P	



**Electric actuators
SAR 07.5, SAR 10.1
Auma**

Technical data

Type	SAR 07.5	SAR 10.1
Marking in valve specification No.	EAG	EAJ
Voltage	380 or 400 V	
Frequency	50 Hz	
Motor power	See specification table	
Control	3 - position control or with signal of 4 - 20 mA	
Nominal torque	60 Nm	
Stroke	25 mm	
Enclosure	IP 67	
Process medium max. temperature	Acc. to used valve	
Ambient temperature range	-25 to 60°C	
Ambient humidity limit	100 %	
Weight	20 - 25 kg	

Specification of Auma actuators

Type	Control	SA	X	XX	XX.X
Duty	Normal	SA	R		
Execution					
Actuator size	07.5				07.5
	10.1				10.1

Output shaft type A (connection flange size F10, thread 36x6)

Output speed (rpm)		Tripping torque	SAR 10.1	Motor power [kW]	SAR 10.1
	4		60-120 Nm		0,09
	5,6				0,09
	8				0,18
	11				0,18
	16				0,37
	22				0,37
	32				0,75
	45				0,75

Output shaft type A (connection flange size F10, thread 36x6)

Output speed (rpm)		Tripping torque	SAR 07.5	Motor power [kW]	SAR 07.5
	4		30-60 Nm		0,045
	5,6				0,045
	8				0,09
	11				0,09
	16				0,18
	22				0,18
	32				0,37
	45				0,37

Accessories

2 TANDEM switches

Gearing for signalisation of position

Mechanical position indicator

Potentiometer 1x200 Ω

Electronic position transmitter RWG (potentiometer included), 4 - 20 mA, 2-wire

Electronic position transmitter RWG (potentiometer included), 4 - 20 mA, 3/4-wire

Inductive position transmitter IWG, 4 - 20 mA

AUMATIC - for continuous control (specification of accessories acc. to catalogue of producer)

Dimensions of actuators Auma

Normal execution

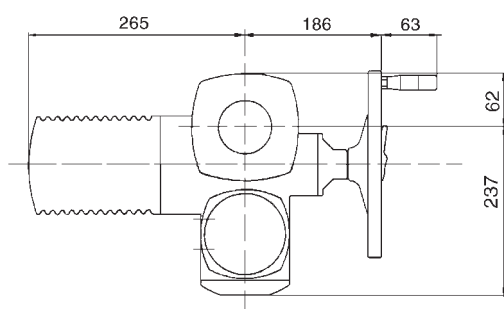

Output shaft type A, connection flange size F10

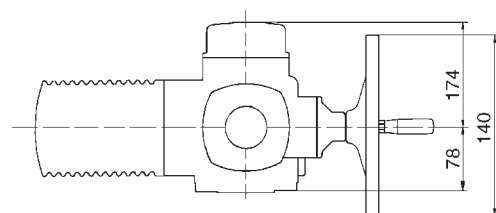
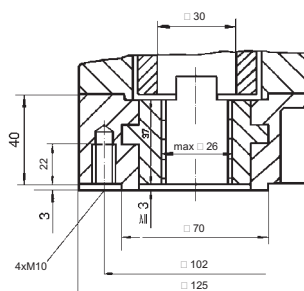

Attachement yoke (4 columns)

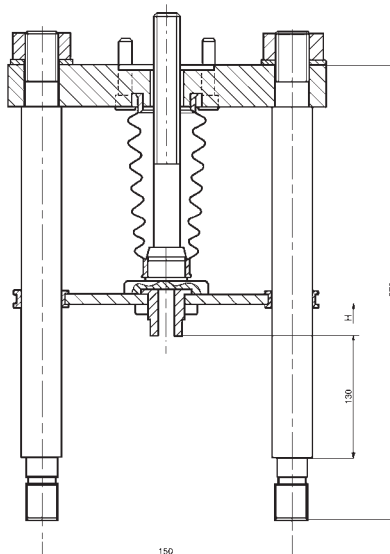

Version with AUMATIC

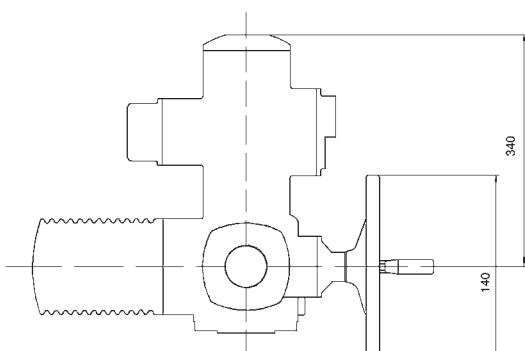
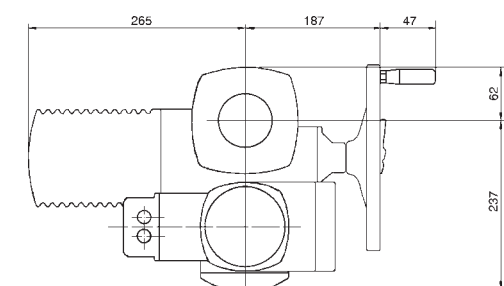



Electric actuators ...AB8 Schiebel

Technical data

Type	rAB8
Marking in valve's specification No.	EZK
Voltage	400 / 230 V; 230 V
Frequency	50 Hz
Motor power	See specification table
Control	3 - position or with signal of 4 - 20 mA
Nominal force	60 Nm
Stroke	25 mm
Enclosure	IP 66
Process medium max. temp.	Acc. to used valve
Ambient temperature range	-25 to 80°C
Ambient temperature limit	90 % (tropical version 100 % with condensation)
Weight	24 kg

Specification of actuator

		XX	X	AB8	A	X	+	XXX				
Execution		Normal										
Duty		Control		r								
Actuator size				AB8								
Output shaft type (connection flange size F10, thread 36x6)					A							
Output speed [rpm]	Tripping torque	rAB8		rAB8								
		30-80 Nm	Motor power [kW]	400/230V	230V							
				2,5	0,12						0,12	2,5
				5	0,12						0,12	5
				7,5	0,18						0,18	7,5
				10	0,37						0,37	10
				15	0,37						0,37	15
				20	0,55						0,75	20
				30	0,75						1,10	30
40	1,10			1,10	40							
Accessories		Potentiometer 1x1000 Ω						F				
		Double potentiometer						FF				
		Electronic transmitter 4 - 20 mA						ESM21				
		Positioner ACTUMATIC R						CMR				

Dimensions of actuators ...AB8

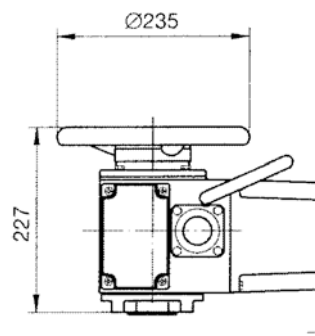
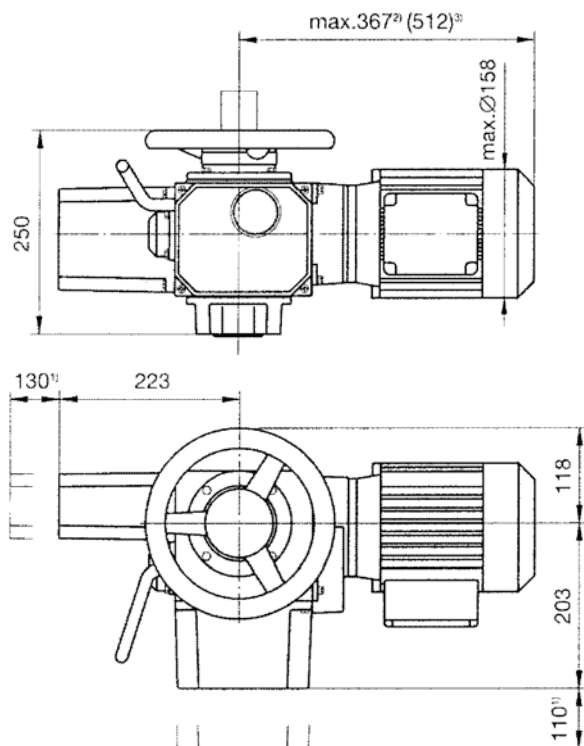

Attachment yoke (4 columns)

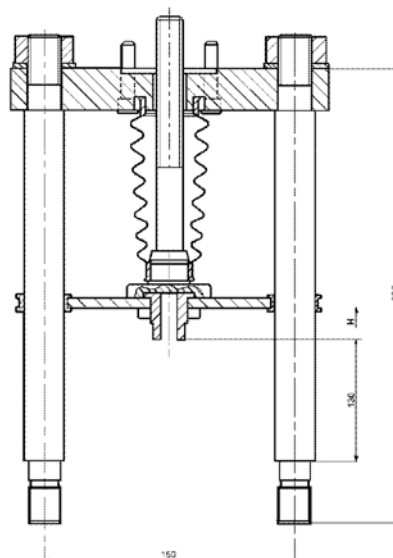
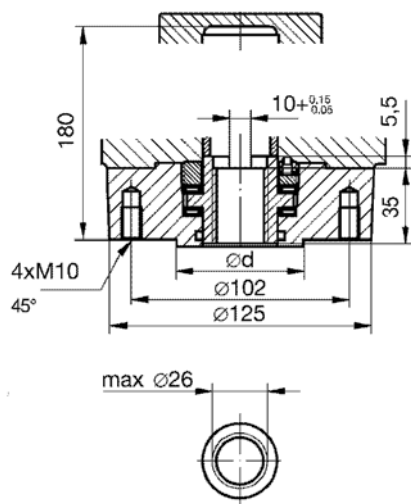



Pneumatic actuators Foxboro

Technical data

Type	PO 1502
Marking in valve specification No.	PFD
Feeding pressure	$p_{max} = 0,6 \text{ Mpa}$, p_{min} -see in tab.
Function	direct indirect
Control	Pneumatic signal of 20 - 100 kPa Current signal of 0(4) - 20 mA
Nominal force	According to table of nominal force values
Stroke	60 mm
Enclosure	IP 54
Process medium max. temperature	According to used valve
Ambient temperature range	-40 to 80°C
Ambient humidity limit	95 %
Weight	See table of dimensions

Accessories

Electropneumatic positioner (analogous) type SRI 990	Device with electric input of 4 to 20 mA and outlet of controlling air into actuator. It is adjusted by switches and potentiometers.
Electropneumatic positioner (intelligent) type SRD 991	Device with electric input of 4 to 20 mA and outlet of controlling air into actuator. It is adjusted by PC and special software. Communication HART, Fieldbus Foundation, PROFIBUS.
Electropneumatic positioner (digital) type SRD 991 - D	Device with electric input of 4 to 20 mA and outlet of contr. air into actuator. It is adjusted by a local keyboard and diods, possibly on display.
Pneumatic positioner type SRP 981	Device with pneumatic input of 20 to 100 kPa to control the pneumatic actuators with pneumatic control signal
Signalisation switches type SGE 985	Adjustable end position switches
Air set type A 3420	Reduces control air pressure to a value requied
Electropneumatic positioner type SRI 986	Analog positioner with input signal of 4 (0) - 20 mA

Operating conditions

Pneumatic actuators FOXBORO can operate with extremely high ambient temperatures with unique resistance to shock loads. They excel with resistance to vibrations and reached 10^6 of cycles in operation. It is possible to deliver the actuator with both fail to open and fail to close function, possibly with a position blocking (air lock) upon feeding pressure air supply failure. Various accessories can be delivered together with the actuator.

Direct and indirect functions

Direct function ensures that actuator's stem retracts upon control air supply failure (valve opens).
Indirect function ensures that actuator's stem extends upon control air supply failure (valve closes).

Dimensions and weights of Foxboro actuators

DN	Actuator	H	A	B	G	M	V1	V2	m [kg]
25, 40, 50	PO 1502	25	550	150	M20x1,5	160	308	409	148

Note: Face to face dimensions [mm]

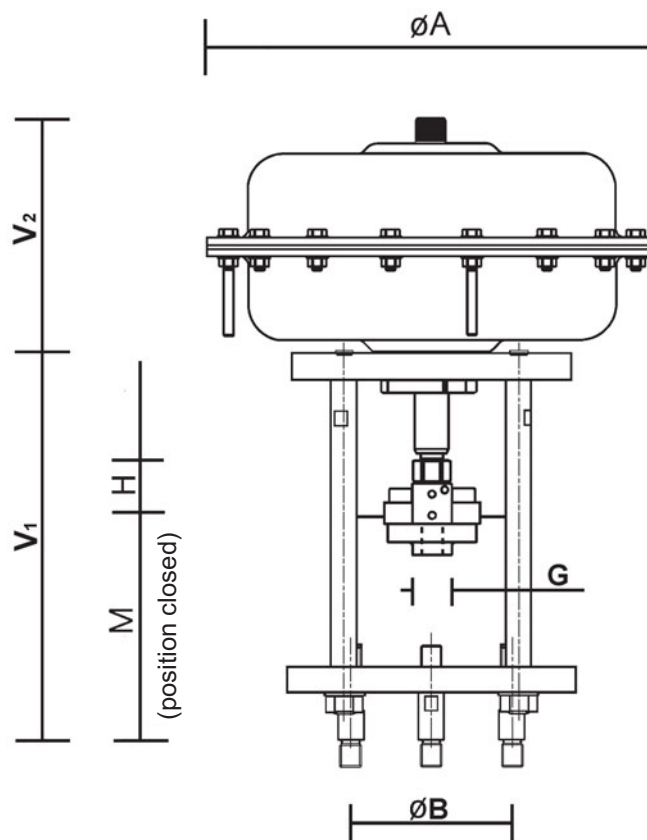

Valve specification No. of Foxboro actuators

		PX XXXX	X XX	X X	X X
Actuator type		PO 1502			
Colour	white		B		
Spring range [bar]	2,0 - 3,5		FS		
	1,5 - 2,7		VC		
Hand wheel	without wheel			O	
Function	direct				A
	indirect				Z
Stroke [mm]	60				C

DN	Actuator type	Function	Actuator's stroke [mm]	Spring range [bar]	Setting of spring [bar]	Feeding min. [bar]
25, 40, 50	PO 1502 BFSOZC	Fail to close	60	1,5 - 2,7	2,2 - 2,7	5
	PO 1502 BFSOAC	Fail to open	60	2 - 3,5	2 - 2,6	5

Maximal permissible pressure values acc. to EN 12 516-1 [MPa]

Material	PN	Temperature [°C]									
		200	250	300	350	400	450	500	525	550	575
Cast steel 1.0425 (11 416.1)	160	11,4	10,4	9,4	8,8	8,4	---	---	---	---	---
	250	17,8	16,2	14,7	13,7	13,2	---	---	---	---	---
	400	28,4	26,0	23,5	21,9	21,1	---	---	---	---	---
Alloy steel 1.7335 (15 121.5)	160	14,9	14,3	13,3	12,3	11,5	10,7	8,9	---	---	---
	250	23,3	22,3	20,8	19,3	18,0	16,7	13,9	---	---	---
	400	37,4	35,7	33,3	30,9	28,9	26,7	22,3	---	---	---

Notes :